

## Synthra RNplus Research (Catalog No. 004r)

Synthra RNplus Research is a flexible and completely automated radio synthesis system for routine production of wide variety of [ $^{18}\text{F}$ ]fluorine labeled compounds by nucleophilic substitution, with automated sequences created for each of them. As the bigger sibling of the RNplus, this module offers additional HPLC and SPE units and overall greater versatility for the production of nearly any [ $^{18}\text{F}$ ]tracer. With the easy-to-use configuration software SynthraView, the Synthra RNplus Research module offers both, fully automatic and manual modes of operation.

### [ $^{18}\text{F}$ ]Labeling Possibilities

- ✓ Synthesis of [ $^{18}\text{F}$ ]-labeled compounds like F-DOPA, FDG, FLT, FHBG, FDDNP, MISO, FAZA and Fluorocholine
- ✓ Simple creation of user-defined synthesis methods
- ✓ Uses a dedicated sub system for the **recovery and collection of [ $^{18}\text{O}$ ]H $_2\text{O}$**  for the purification of the cyclotron produced [ $^{18}\text{F}$ ]fluoride.
- ✓ The target activity is measured with a separate detector.

### General Features

- ✓ **Heating and cooling capabilities**
  - Three heating zones with cooling capabilities
  - Temperature range: -50 °C – 200 °C
- ✓ **Detectors and controllers**
  - Five shielded radiation detectors
  - Four Pressure sensors
- ✓ **Built-in preparative radio/UV-HPLC system** with quaternary gradient pump, variable wavelength LED detector with a range from 190 nm to 900 nm, column switching valve, two HPLC columns and two solid phase extraction (SPE)
- ✓ **Dispensers and valves**
  - HR-dispenser (up to 50.000 steps, 5 mL)
  - HPLC pneumatic injection valve (3 mL sample loop)
  - Three spare valves for customization
  - Chemically inert valves with small dead volume < 35  $\mu\text{L}$ , 5 bar rated

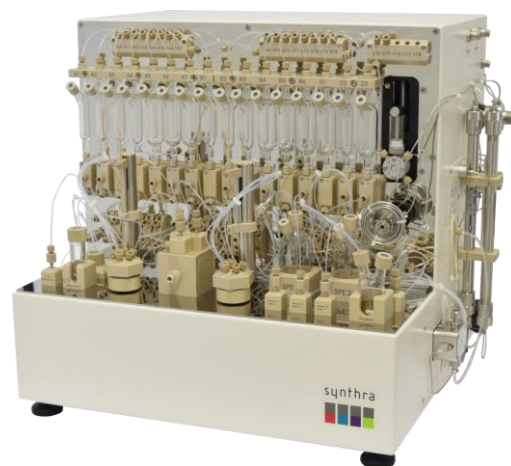

- ✓ **Build-in vacuum pump** (< 5 mbar)
- ✓ **Liquid nitrogen trap** for protecting the vacuum pump from radioactive volatiles
- ✓ **Self-Cleaning System**
- ✓ **Size** (w x d x h): 52 x 50 x 48 cm
- ✓ **Weight**: approx. 35 kg

### Synthesis Features

- ✓ Two glassy carbon **reaction vessels** (one is 5 ml, conic shape and the other 11 ml) and one **column oven** for a solid support reaction zone, allowing multiple step (homogenous and heterogeneous) synthesis reactions. On request, an adapter for using a 3 mL glass vessel can be provided.
- ✓ **16 reagent vials**
  - Eight small (1 – 3 mL) and eight large (10 – 15 mL) volume glass vials for reagents
- ✓ **Eight cartridge holders** for in-process purification
- ✓ **SPE unit** for final product formulation

# Synthra C-11 Family

## Product Description and Technical Specifications

synthra



### Additional Synthesis Options

- ➔ **Product solvent evaporator**  
(Catalog No. 000pse)

### GMP Features

- ✓ Synthesis files for various tracers available
- ✓ **GMP compliant.** Electronic control and data collection (27/18 channels)
- ✓ **21CFRpart11 & LIMS** compatible

### Terminal Control

- ✓ A laptop (Win 10 Pro) with preinstalled controlling software SynthraView is included
- ✓ Four digital inputs for communication with external devices upon request

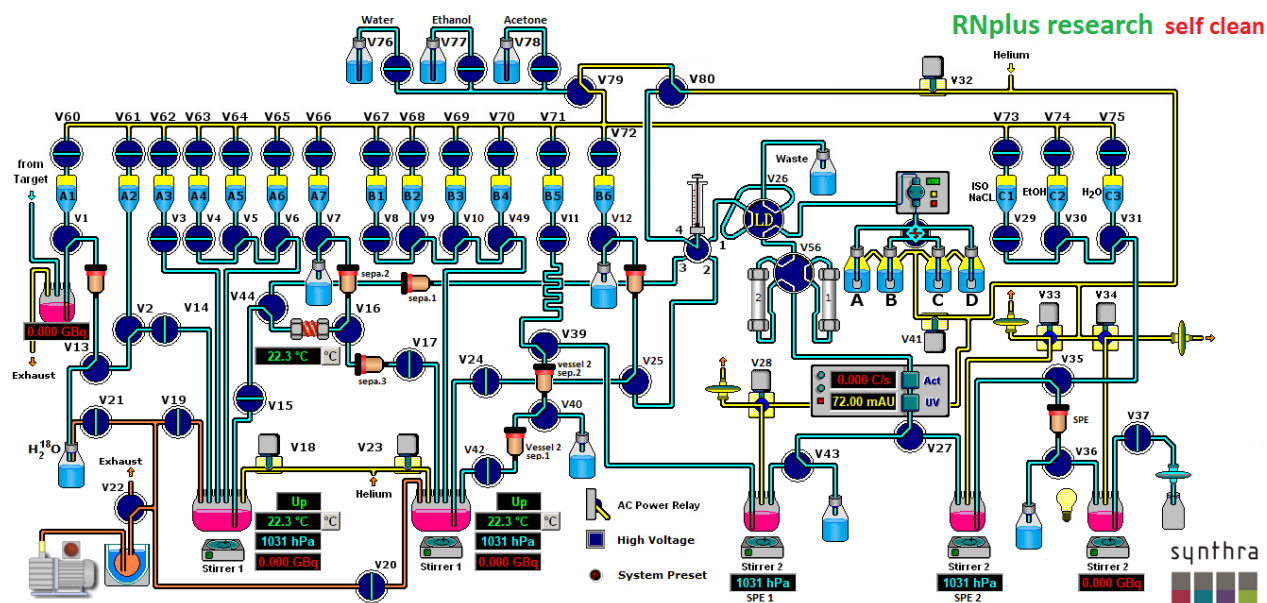

The Graphical User Interface (GUI) of the SynthraView software.